



DIGITAL FLOWMETER (Including Rev. 3.0) INSTALLATION & MAINTENANCE

Model	Schedule 40 Pipe Size	Calibrated Range
9090	1/2 NPT Pipe	1-90 SCFM (2-153m ³ /hr)
9091	3/4 NPT Pipe	1-120 SCFM (2-204 m ³ /hr)
9092	1 NPT Pipe	1-160 SCFM (2-272 m ³ /hr)
9093	1-1/4 NPT Pipe	2-150 SCFM (3-255 m ³ /hr)
9094	1-1/2 NPT Pipe	2-200 SCFM (3-340 m ³ /hr)
9095	2 NPT Pipe	4-400 SCFM (7-680 m ³ /hr)
9096	2-1/2 NPT Pipe	5-500 SCFM (8-850 m ³ /hr)
9097	3 NPT Pipe	12-1200 SCFM (20-2039 m ³ /hr)
9098	4 NPT Pipe	20-2000 SCFM (34-3398 m ³ /hr)
9099	5 NPT Pipe	20-2500 SCFM (34-4248 m ³ /hr)
90100	6 NPT Pipe	50-5000 SCFM (85-8495 m ³ /hr)
90101	8 NPT Pipe	60-6000 SCFM (102-10194 m ³ /hr)
Any of the following suffixes may be added to a model number to alter the flowmeter as listed. Please check with an application engineer if you have any questions.		
-DG	Does not include Drill Guide	
-DAT	Includes Data Logger - See Lit 9021 for operation of Data Logger	
Z	Wireless Compatible - See Lit 9018 for more information	
ZG	Wireless Compatible and includes Gateway - See Lit 9018 for more information	
-M3	Calibrated for Cubic Meters	
Examples:	9090-DG does not include Drill Guide 9090-DAT includes the Data Logger (1/2 NPT DFM without Drill Guide) 9090-DG-DAT does not include Drill Guide, includes Data Logger (1/2 NPT DFM with Data Logger) 9090Z has wireless capability 9090ZG has wireless capability and includes Gateway 9090-M3 is calibrated for cubic meters (Necessary for Rev. 2 meter only.)	

Specifications	
Accuracy	Calibrated Range: 5% of reading, plus 1% of full scale for air temperatures between 40° and 120°F (4° - 49°C). Extended Range: For flows up to 50% more than maximum calibrated range, accuracy is 7% of reading for air temperatures between 40° and 120°F (4° - 49°C).
Operating Pressure	30 to 140 PSIG for best accuracy – 200 PSIG max
Power	Power Adapter requires 100-240VAC, 0.6A Outputs 250mA at 24VDC
Wetted Materials	Stainless steel, gold, thermal epoxy and Viton (seal)
Ring Material	Aluminum
Display	Four-digit LED display
Compliance	CE and RoHS

Note: For use with compressed air and nitrogen only.

Application

The Digital Flowmeter may be used with either compressed air or nitrogen, at pressures from atmospheric to 200 PSIG. The air or nitrogen must be free of oil and suspended water droplets. Refer to the “Flowmeter Accuracy” above for the calibrated range of the particular meter. The meter will continue to read at much higher flow rates, but there may be significant inaccuracy.

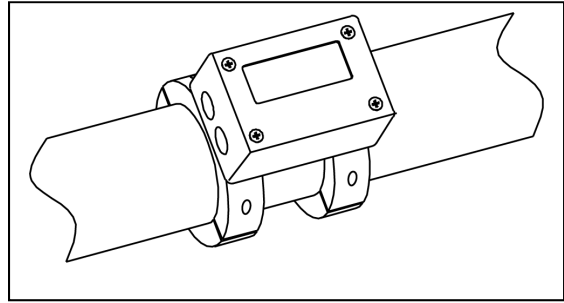

Location

The Digital Flowmeter may not be installed in a hazardous location. For installation in areas exposed to moisture, please contact an Application Engineer. Rev 3.0 meters meet NEMA 4 requirements. For best accuracy, the Digital Flowmeter should be installed with at least 30 diameters of straight pipe upstream and five diameters downstream. (Example: 30 diameters for a 1" Schedule 40 pipe = 30 X 1" = 30" of straight pipe.)

Avoid installing the Digital Flowmeter downstream of any item that could distort or concentrate the flow, such as a partially-closed valve, a regulator, a filter or moisture separator, two closely-spaced elbows in different planes, a long-radius elbow, an increase in pipe size or a curved hose. For these situations, allow at least 50 diameters of straight pipe between any such item and the meter. Select a location that meets these requirements and also provides good visibility from the plant floor.

Preparing the Holes

Shut down the compressed air system where the Digital Flowmeter will be installed and make sure that it will remain shut off during installation. Discharge the air from the pipe prior to drilling.

Mounting is easiest using the drill guide kit that includes a 3/16" drill bit and locating fixture. Secure the hole locating fixture to the pipe with a C-clamp, hose clamp, or a chain clamp. On pipes one inch and smaller, use the backing piece provided. If using a C-clamp, make sure that it is centered across the pipe. Drill the holes, making sure to go through one wall of the pipe only. Remove the hole locating fixture, and remove any burrs that were formed when drilling.

When the holes are drilled, metal shavings will enter the pipe. Make sure that filters or other provisions are present downstream to prevent the shavings from damaging downstream equipment, tools or products as well as considering any place where they could be blown out and cause an injury.

Installing the Meter

The probes of the Digital Flowmeter must be clean before inserting them into the pipe. Remove any oil or dirt using alcohol or a similar degreaser. Insert the probes into the holes of the pipe making sure the flow arrow is pointing in the proper direction. Tighten the screws carefully, alternating screws so that the two sides of the collars are pulled together evenly. If the LED display is upside down, remove the cover of the meter, gently pry the circuit board with the display loose, rotate it 180 degrees, and reinstall the cover. If the yellow caution label is not visible, apply the extra caution label from the bag of parts so it is in a visible location.

Power Supply

Use the 24 VDC power supply that is provided with the meter. Power Supply requires 100-240VAC. (Note: The 18 volt power supply provided with the previous version will not work with the Rev 3.0 meter.)

Milliamp Output

The mA- and mA+ terminals are optically isolated from the remainder of the circuit and may be wired as part of an externally-powered loop. When this is done, the jumper that is supplied with the meter must be removed. If you use an external power supply, be sure that it has sufficient voltage to overcome an 8.2 volt drop within the meter in addition to any other voltage drops in the loop.

Alternatively, the meter's supply may be used to power the milliamp signal. Leave the jumper in place from the supply+ terminal to mA+. Wire from the mA- terminal to the positive side of the external receiver and from the negative side of the external receiver to the supply terminal. Note that the supply terminal is connected to the aluminum rings, and thus is normally connected to the pipe on which the meter is mounted.

Pulse Output

The pulse output is a transistor switch connected to the meter's negative supply. To use the output, connect it to an input of the receiving device (usually a counter or PLC) and connect a pull-up resistor from that input to a positive supply suitable for the receiving device. Also connect the negative supply terminal of the meter to the negative supply of the receiving device.

Using the Display – Rev 3.0 meters only

The button that controls the display is marked by a circle on the side of the meter. After the power is turned on, pressing the button will cycle through (4) display options: RATE, DAILY USAGE, CUMULATIVE USAGE and UNITS OF MEASURE.

The RATE is rate of air the meter is measuring.

The DAILY USAGE mode displays the usage in thousands of standard cubic feet during the most recent full 24-hour recording period. Holding the button while in this mode will reset the value to zero.

In the CUMULATIVE USAGE mode, the display shows the total air usage in thousands of standard cubic feet. After reaching 9999, it rolls over to 0. It can be used to track monthly air usage and allocate utility costs. The decimal point can be placed to provide better resolution than one thousands of standard cubic feet, but the display will roll over sooner. Holding the button while in this mode will reset the value to zero.

The UNIT OF MEASURE indicates the unit of measure: "0" indicates SCFM, "1" indicates m³/min and "2" indicates m³/hr.

Customizing the Display – Rev 3.0 meters only

The button that controls the display is marked by a circle on the side of the meter. Hold the button while the power is off, then apply power to the meter and release the button. The letters "AC" for access code will appear. Press the button repeatedly to cycle to the number 4. After a few seconds, the letters "dd" for default display will appear. Use the button to cycle through the options for the default mode; a "0" indicates rate mode, a "1" indicates daily usage mode, and a "2" indicates cumulative usage mode. Wait, and the letters "dP" for decimal point will appear. Press the button repeatedly to move the decimal point to the desired position for the daily and cumulative usage modes. The letters "du" for display unit will then appear. Cycle through the options for the default units as listed here:

0. Rate in SCFM, daily and cumulative usage in 1000 ft³.
1. Rate in m³/min, daily and cumulative usage in 1000 cubic meters.
2. Rate in m³/hr, daily and cumulative usage in 1000 cubic meters.

The meter will then return to normal operation.

Using the Outputs

The milliamp output is scaled so that 4 milliamps corresponds to zero flow and 20 milliamps corresponds to a flow rate that is above the calibrated range. There are two ways to determine the flow rate corresponding to 20 milliamps for a particular meter. The first is to look at the sticker inside the meter; it gives both the calibrated full-scale flow and the milliamp range. The second way is to press the button on the main circuit board twice. On the first press, the display will indicate zero and the meter will output four milliamps; and on the second press the display will indicate the full-scale value and the meter will output 20 milliamps. The pulse output generates a square wave signal, sending five pulses for each cubic foot of air that passes through the meter. The LED blinks with the pulse output. At zero flow it may be on or off.

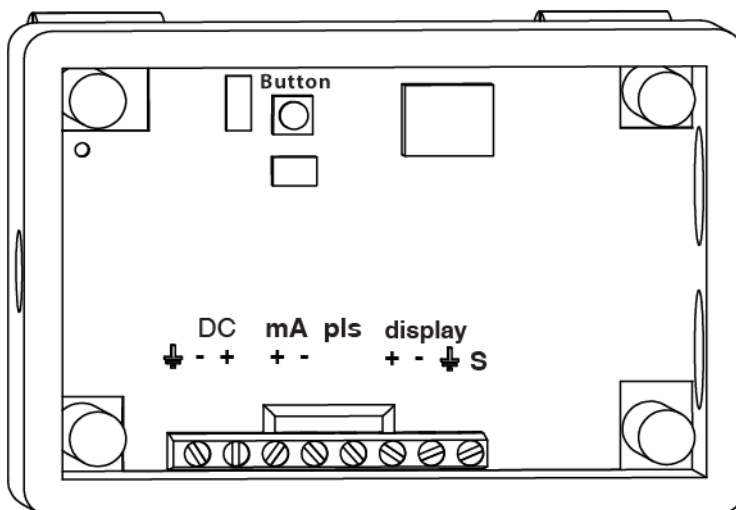

**Shown with top circuit board
Removed for clarity**

Maintenance

If oil or dirt accumulates on the probes, the meter will read low. For this reason, we recommend cleaning the probes from time to time. To clean the probes, wipe them with a cloth dampened with alcohol or a similar degreaser.

If you have any questions or problems, please contact an EXAIR Application Engineer at:

Toll Free: 1-800-903-9247 (U.S. & Canada)
 Telephone: 513 671-3322 outside of U.S. & Canada
 Toll Free Fax: 866-329-3924 (U.S. & Canada)
 FAX: 513 671-3363 outside of U.S. & Canada
 E-mail: techhelp@exair.com
 Website: www.exair.com